



White Paper

March 2005

Cool RF sub-system enhances UMTS WCDMA Cell Coverage

Ian Beeby, Cryo Systems

Abstract

This paper presents a novel RF sub-system that offers substantial improvements in cellular communications up-link performance when compared to legacy systems. Through the use of state of the art superconducting filter technology and a cooled RF pre-amplifier, this new system promises to revolutionise cellular planning and performance budgets by increasing the cell area by up to 180%. Capable of operating between 500MHz and 15GHz, this paper demonstrates performance improvements with WCDMA cellular systems.

How it works

The system, known as a **cTMA** or **cool Tower Mounted Amplifier**, is based around an innovative microwave system on-a-chip which incorporates all of the required microwave components including a pre-amplifier and a cooler. Using high-temperature superconducting ('HTS') materials it is possible to realize filter elements with Q factors of 80,000 to 400,000 leading to a system performance that cannot be matched using conventional low-loss technologies.

In addition, cooling a conventional GaAs FET amplifier device to 60K reduces its noise figure without impacting performance, leading to an effective replacement front-end for most cellular base station systems.

In a legacy cellular base station the receiver is located in a cabinet at the base of the antenna tower and is fed by means of low-loss co-axial cable. Even with high-quality cables and connectors the losses and noise figure are increased significantly due to the height of the tower. Indeed, typical legacy cellular base stations have system noise figures of around 5dB due to the necessity to have filters before the pre-amplifiers in order to reduce out of band interference.

With the cryogenic **cTMA**, however, system noise figure can be reduced to around 0.5dB leading to substantial performance enhancements for these legacy systems. The CryoSystems **cTMA** operates at 60K using an ultra-reliable Stirling cooler in a backpack sized unit that is sealed for life. With a mass below 25kg, the unit presents minimal structural and wind-loading impact for the tower designer to contend with.

The System Noise Figure

The most significant benefit to any radio receiving system is a reduction in the system noise temperature with a consequent reduction in the minimum discernable signal level. Weaker signals can be detected. Range is improved.

In a typical receiver, the system noise temperature is dominated by the first 3-5 elements. If a pre-amplifier is placed close to the antenna, as long as its gain is sufficient to overcome the attenuation of the subsequent cable and the noise of the first mixer (or second amplifier), the system noise figure will be dominated by the first three stages as shown in Figure 1 below:

Cool Improvements

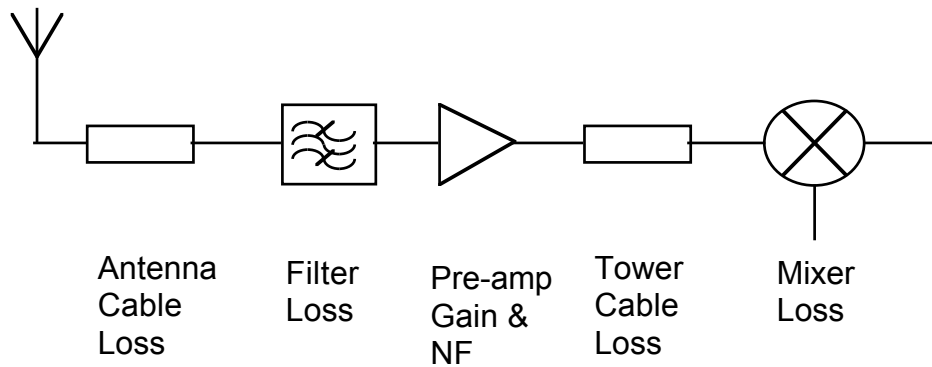

Fig. 1: Contributions to Receiver Noise Temperature

The noise figure of the system is determined by the standard cascaded noise temperature equation due to Friis^{1,2} thus:

$$F = F_1 + \frac{F_2 - 1}{G_1} + \frac{F_3 - 1}{G_1 G_2} + \dots + \frac{F_n - 1}{G_1 \dots G_n}$$

where 1-n represent the cascaded stages in order. In most cases, the pre-amplifier gain is sufficient to prevent the noise figure of the succeeding stages from being a significant contributor. The receiver performance is directly determined by the early stage losses and noise figure. Passive stage noise figure is usually taken as the stage loss. Therefore a length of cable plus connectors with overall loss of 2dB would be taken to make a gain contribution of -2dB and a noise figure contribution of 2dB.

In comparing the performance of an HTS enhanced system like the CryoSystems **cTMA** with a legacy system we will consider the typical legacy system where there are no tower mounted receiver components.

For the sake of this analysis, the system noise figure will be calculated at the input to the receiver sub-system at the mast-head. We will therefore ignore the antenna (in any case it is common to all systems) and only include the noise contribution from feeder, filter and pre-amplifier stages.

Of particular importance in considering the system noise figure is the contribution made by the parts of the system that are cooled. In the case of the filter, its noise contribution will reduce as the ratio of its absolute temperature to the system reference temperature (traditionally 290K) so that a filter with a nominal loss of L operated at temperature T will have a noise contribution of

$$F = 1 + (L - 1) \frac{T}{T_0}$$

where F is the noise figure and T₀ is the reference temperature (290K). When T is 60K the noise figure is approximately 1/5 the insertion loss of the device. For these calculations the following assumptions will be made:

	Legacy BTS	cTMA
Cable Loss	2.0dB	0dB
Filter Loss	2.0dB	0.1dB
Amplifier Gain	12dB	12dB
Amplifier NF	0.5dB	0.3dB
Temperature	290K	60K

Table 1: Losses and Noise Figures compared

¹ Noise Figure Notes: http://moon.pr.erau.edu/~lyallj/ee410/noise_fig.html

² Hess, Garry, 'Land Mobile Radio System Engineering', Artech House, 1993, pp26-28

Cool Improvements

Benefits of reduced noise figure

We can re-arrange link budget and capacity equations to see how the cell coverage is affected by the receiver noise figure. Lindskog and Trott³ derived the notional cell radius of a CDMA system, R, as

$$R = r_0 \left(\frac{P_t}{S} \right)^{\frac{1}{\gamma}}$$

where γ is a path loss exponent, r_0 is a constant, P_t is the transmit power of the terminal and S is the received signal energy given by

$$S = \frac{N_f N_0 W}{N_{pole} \alpha (1 + \beta) \left(1 - \frac{N}{N_{pole}} \right)}$$

From this we can see that

$$R \propto N_f^{-\left(\frac{1}{\gamma}\right)}$$

The cell radius achievable with a CDMA system is therefore proportional to the noise figure of the receiver raised to the power $-\frac{1}{\gamma}$. The cell area A is similarly proportional:

$$A \propto N_f^{-\left(\frac{2}{\gamma}\right)}$$

Typically, values for γ range from 2.5 to 4.5 representing rural through dense urban terrain (whereby the normal propagation is affected to a greater extent by the surroundings).

From this we can estimate the increase in cell coverage area as a function of the noise figure improvement. However, it must be remembered that real-life propagation conditions may not permit this improvement to be realized in all circumstances.

In a free space environment, $\gamma = 2$, resulting in

$$A \propto \frac{1}{N_f}$$

If the noise figure is reduced from 5dB to 0.5dB we should therefore expect a 180% increase in free-space cell radius, all other things being equal. The table below tabulates the improvements obtainable over a legacy BTS configuration with a 5dB noise figure and a CryoSystems **cTMA**.

	Legacy BTS	cTMA
Noise Figure	5dB	0.5dB
Proportional Cell Area	1	2.8
Increase in Area(%)	n/a	180

Table 2: Proportional increase in free-space coverage as noise figure is reduced

In practice the value of γ depends upon the environment and is an empirically derived factor. Rappaport et

³ Capacity and Coverage Improvements of adaptive antennas in CDMA Networks', Lindskog, E, and Trott, M, ArrayComm Inc, May 2001

Cool Improvements

al⁴ presented a table of typically used values for γ :

Environment	Path Loss Exponent, γ
Free Space	2
Urban area cellular/PCS	2.7 - 4.0
Shawowed urban cellular/PCS	3 - 5
In-building line-of-sight	1.6 - 1.8
Obstructed in-building	4 - 6
Obstructed in factories	2 - 3

Table 3: Propagation factor, γ , for different environments

Maximum coverage improvement vs noise figure improvement as a function of γ is shown in figures 2 and 3 below:

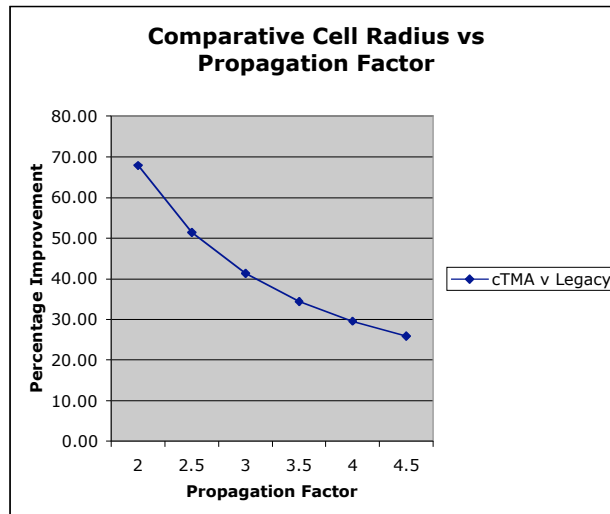

Fig. 2: *cTMA* Cell Radius Improvement vs γ

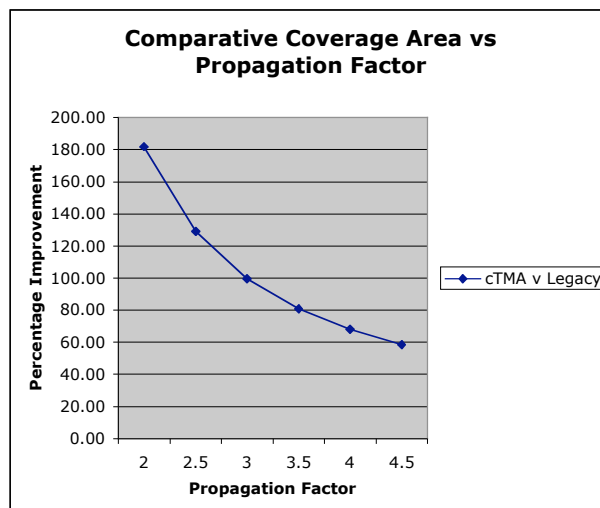

Fig. 3: *cTMA* Improvement in Cell Area vs γ

⁴ 'Propagation and Radio System Design Issues in Mobile Radio Systems for the GloMo Project', Rappaport, T. S. et al, January 1997, Virginia Polytechnic Institute/DARPA

Cool Improvements

Very significant improvements can be seen for both rural and urban environments which typically will result in reducing the number of base stations and a resultant lower capex and opex for Operators. In more densely built-up areas, intra-cell interference is more significant for CDMA systems and any improvement in link budget can impact the dropped call rate significantly with immediate and positive customer satisfaction benefits.

The CryoSystems **cTMA** offers dramatic improvement over a legacy base station configuration in cell radius and coverage area, propagation limitations notwithstanding. In free-space conditions ($\gamma=2$), the **cTMA** offers over 180% greater coverage area or nearly 70% greater cell radius than a legacy system. In a typical urban area ($\gamma=3$) these improvements are approximately a 100% increase in coverage area or more than 40% increase in cell radius.

Summary

The use of a cryogenic receiver at the mast head can effect substantial coverage improvements for CDMA cellular systems. These improvements are most noticeable in the rural coverage-driven parts of the network but still substantial in urban areas where cell overlap can be increased thereby improving soft hand-over gains. The CryoSystems **cTMA** offers a substantially greater benefit than a conventional TMA when compared with a legacy base station design.

Furthermore, the substantially reduced size of the CryoSystems **cTMA** compared to its nearest competitor makes it ideally suited for installation on low structural mass antenna towers typically being deployed in Europe and elsewhere today.

About the Author

Ian Beeby has over twenty years' experience in RF and telecommunications systems engineering. He graduated with honours in Physics with Electronics from the University of Southampton, England, in 1984. Following a successful career in the defense industry, during which time he worked in antenna systems design, communications system engineering and electronic warfare, he moved to telecommunications network planning in 1992. Ian has been working as a telecommunications consultant since 1997. He is registered with FEANI at Stage 1 (Eur. Ing.), a Chartered Engineer, a Chartered Physicist, a Chartered Scientist and is a Member of the Institute of Physics and the IEEE.

Datasheet - CryoSystems **cTMA**

Dimensions:	51cm (w) 37cm (h) 18cm (d)
Mass:	25 Kg
Operating limits:	-40 to +60°C 100% RH
Frequency band:	GSM 900, 1800, 1900 & UMTS
Pre-amplifier gain:	12-20dB, (selectable)
Filter performance:	Selectable
Power:	<160W / 48VDC

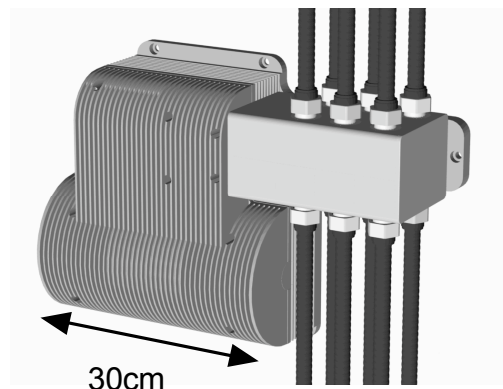

Contact:

CryoSystems Limited
Eaton House
Eaton Green Road
LUTON
GB-LU2 9LD

CryoSystems **cTMA**

Tel: +44 1582 416699
Fax: +44 1582 726840
E-mail: enquiries@cryosystem.com
Web: <http://www.cryosystems.co.uk>

Document ID: CSWP01200503US